

# REAL AMERICAN MADE POWER

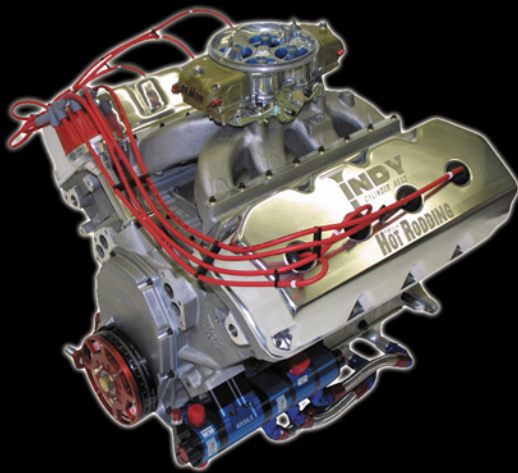

**Crate Engines    Cylinder Heads**

**Manifolds    Engine Blocks**

**Short Blocks    Rotating Assemblies**

**Fuel Injection    CNC Porting**

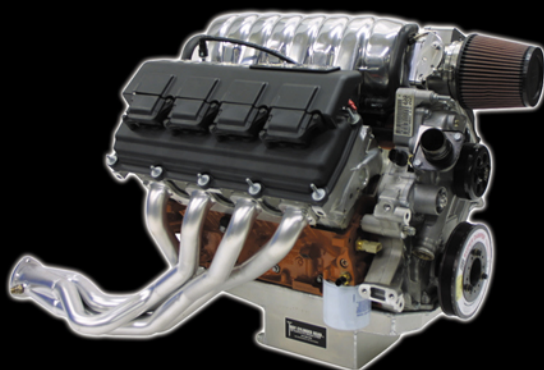

**CATALOG 2007**

# CRATE MOTORS

*We're using our knowledge from the past...*

526 "Who's Next?" Street legend

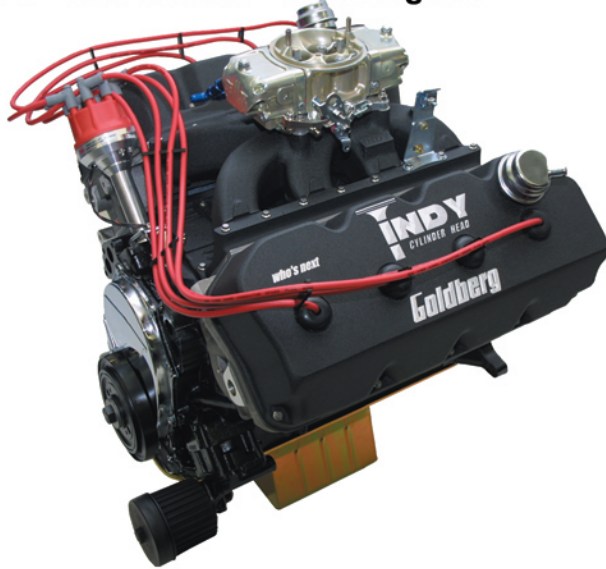

The 605 Street Legend

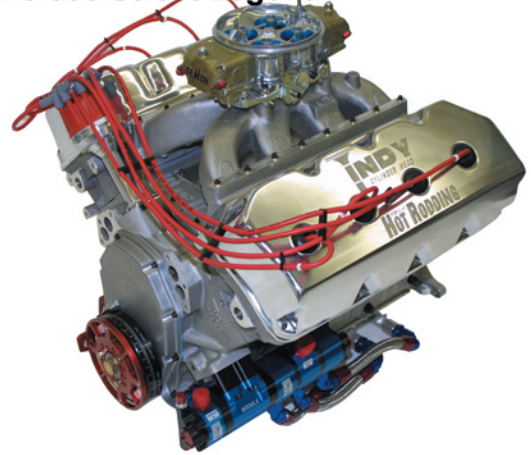

New Accessory Drive

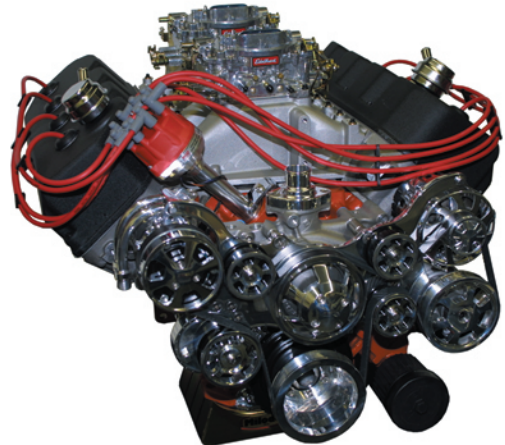

**100%  
CNC  
Ported**

*Let us design and  
build an engine to  
your specifications*

**WIND JAMMER**  
CNC PORTING

ICH offers our complete line of heads (Wedge, Legend, Small block Chrysler and AMC fully 100% CNC ported. CNC porting allows us to take years of porting development and replicate ports and chambers from one head to another. The result: more horsepower from heads that have matching port volumes and flow numbers every time.

***to provide you power in the future!***

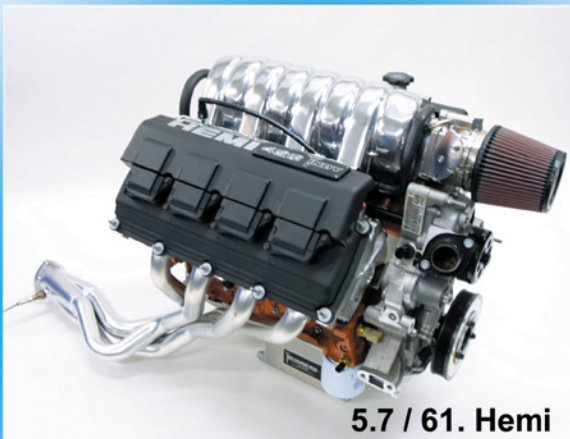

5.7 / 61. Hemi

This is what it's all about!

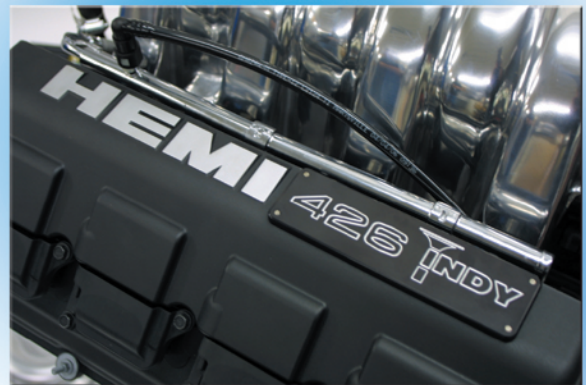

# About Indy Cylinder Head



## About Indy Cylinder Head

Located in the heartland of America, Indianapolis Indiana, Indy Cylinder Head can trace it's beginnings back to the race track. Over 35 years ago we developed the technology necessary to produce performance cylinder heads. Not just good heads, but great heads. Racers with Indy heads were winning big!

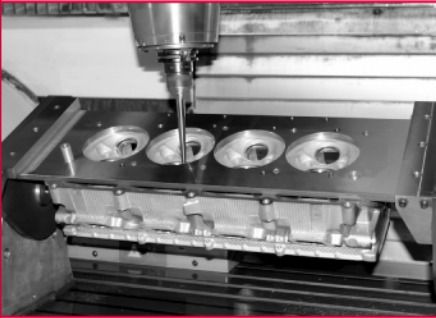
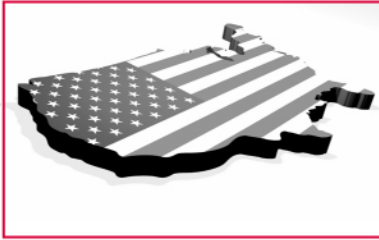

What we learned in the early years was that port volume was the key to horsepower generation. We transferred that knowledge to all Chrysler heads and developed the most extensive line of CNC ported cylinder heads in the industry.

Over the years we expanded from the production of heads to a full line of Chrysler engines and components. You can now buy a fully assembled Chrysler crate motor designed and built to your own specifications.



Fred, Russ and Ken

## Our Product Line

**Wedge crate engines Legend crate engines**  
**Small block crate engines AMC crate engines**  
**Short block kits Rotating assemblies Engine blocks**  
**Neon parts 401 AMC parts Small block parts**  
**Edelbrock parts 440/400 B/RB parts Cylinder heads**  
**Balancers Belt drives Bolts Studs Carburetors**  
**EFI Manifolds Camshafts Crankshafts Gaskets**  
**Headers Ignition parts Valve covers Oil systems**  
**Superchargers Water pumps Starters CNC work**

## Contents

Introduction	2
Wedge Crate Engines	3
Legend Crate Engines	4
AMC Crate Engines	4
Short Block Kits	5-6
Rotating Kits	7
Engine Blocks	8-10
Neon Parts	11
CNC Porting	12-14
401 AMC	15
Small Block Parts	16
Indy Edelbrock Parts	17
440 / 400 B / RB Parts	18
440-EZ B / RB Parts	19
426 Legend Parts	20-21
392 / 426 New Legend Hemi	22
New Legend Hemi Parts	23

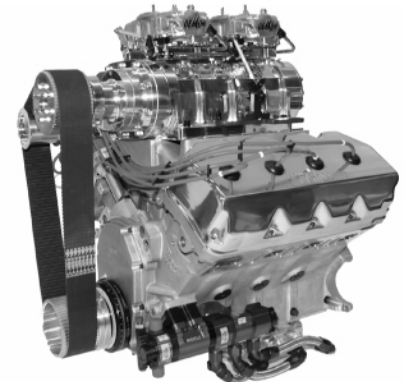

Polished Supercharger Kits Available



# Introduction



*Feel the power!*



For over thirty five years Indy Cylinder Head has been supplying the after-market with high quality engine parts and complete engines. We have always been dedicated to making all Indy racers winners. Our secret is simple. We transferred our years of racing experience into our parts. Through extensive engineering and real world testing we have been able to assemble the correct combinations of blocks, cylinder heads, manifolds, pistons, camshafts and every other engine component used to produce the ultimate in power.

We really understand what is needed to get you there.

After browsing through our catalog and our detailed price sheet, please feel free to call us with any questions you may have.

## Horsepower is all about port volume.

Our success in producing real horsepower has come through our practical understanding of the fact that horsepower generation is **all about port volume**. We discovered early on in the game that the port volume essential for power generation can not be achieved with the industry's shortest valves, the Chrysler intake and exhaust valves.

Realizing that we needed a longer valve, we designed the ports in our 440 cylinder heads around a 1/2 " longer valve. This allowed us to raise the port roof significantly. The modification created the extra port volume required to achieve the desired end result... more horsepower, and lots of it!

Here you can visualize the dramatic difference in port volume between the stock 906 head and the Indy 440-1 head upon overlaying the head diagrams.

Indy 440-1 head cutaway



Stock 906 head Cutaway

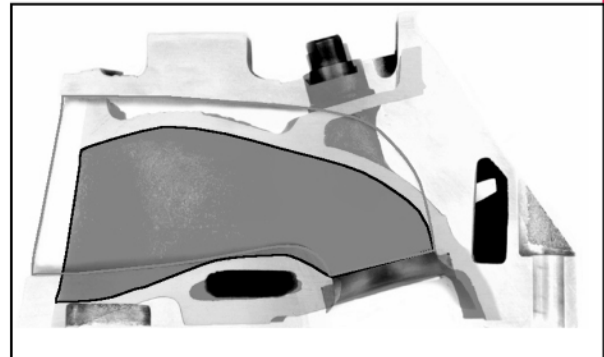
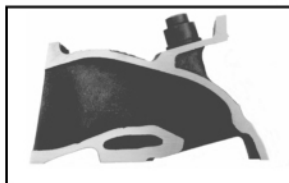

Indy 440-1 cylinder head cutaway overlaid onto a stock 906 cylinder head cutaway

It was with these simple yet important principles that Indy Cylinder Head gained success. We worked very hard in the beginning and continue to work hard to bring you more and more horsepower. Our knowledge of cylinder head porting has been transferred into all our other heads, Legend, 360, 401.



We are always striving to develop new and fresh ideas and to expand our product line to bring you more product choices, as evidenced by the introduction of our new 5.7 / 6.1 series of engines and components. We're using our knowledge from the past to produce more advanced engine products for you in the future.

**New 6.1 426" Hemi**

# Wedge Crate Engines



Based on the 440 or 400 Big Block Chrysler

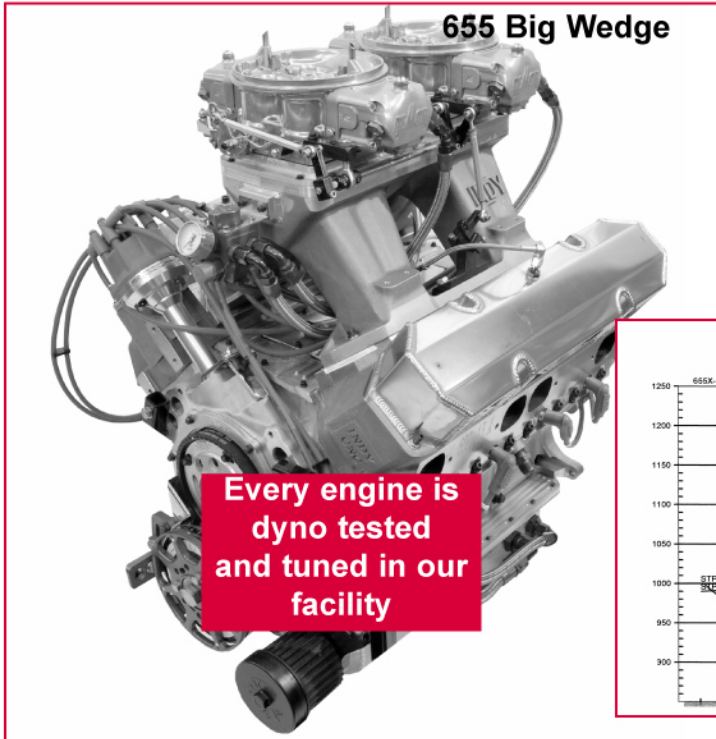

Indy cylinder Head has been the industry leader in the design and manufacture of high performance Chrysler engines for over thirty five years. Every crate motor we produce is designed, assembled, dyno tested and tuned in our Indianapolis facility.

Each engine is built to the customers specifications to assure you of complete satisfaction.

Please feel free to contact us and discuss your needs.

A complete listing of engine specifications and component parts can be found in the price sheet.

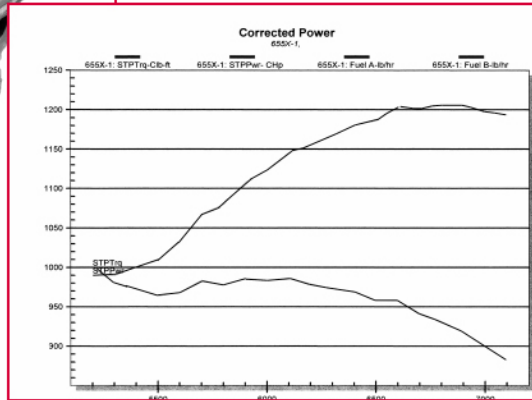

**See page 2 of the price sheet for complete engine specifications**

Engine	Part #	Horsepower	Torque	Fuel
426" B Street Wedge	400-C6-426-525	525 @ 6000 RPM	500@ 4700 RPM	Pump
451" RB Street Wedge	440-C6-451-550	550 @ 5700 RPM	500@ 4500 RPM	Pump
500" RB Street Wedge	440-C6-500-630	630 @ 6200 RPM	575@ 4500 RPM	Pump
500" RB Street Master	440-C6-500-680	680 @ 6700 RPM	620@ 5000 RPM	Pump / race
500" RB Bracket Master	440-C6-500-800	800 @ 7000 RPM	690@ 5500 RPM	Race
528" RB Bracket Master	440-C6-528-820	820 @ 7000 RPM	710@ 5500 RPM	Race
540" RB Street Master	440-C6-540-720	720 @ 6800 RPM	680@ 5100 RPM	Pump / race
540" RB Bracket Master	440-C6-540-860	860 @ 7100 RPM	735@ 5600 RPM	Race
572" RB Bracket Master	440-C6-572-930	930 @ 7200 RPM	810@ 5800 RPM	Race
605" RB Street Master	440-C6-605-750	750 @ 6500 RPM	775@ 4800 RPM	Pump
655" RB Big Wedge	440-C6-655-1200	1200 @ 7400 RPM	1000@ 5800 RPM	Race

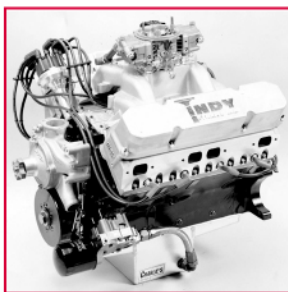

**500RB Street Wedge**

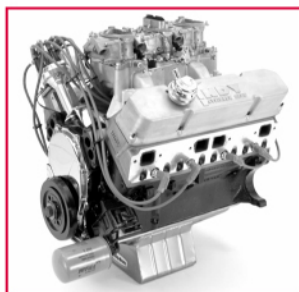

**426B Street Wedge**

See page 2 of the price sheet for the specifications on the Wedge engines.

Component upgrades are available on each engine. Call us to have an engine built to your specifications.

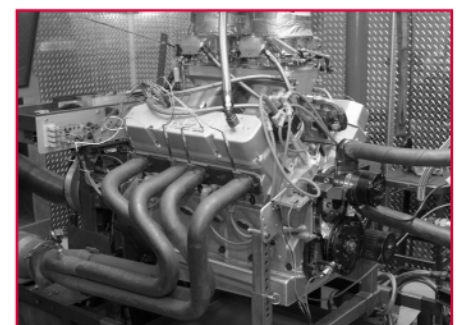

Hemi is a trademark of Chrysler corporation used for identification purposes only



# Legend / SB / AMC Engines

Based on the Chrysler Hemi and 360 Small Block

We offer a series of engines based on the legendary 426 Hemi (Legend Series) the 360 small block or AMC. These engines are manufactured with the same attention to detail and quality as the Wedge series.

Each engine is built to the customers specifications to assure you of complete satisfaction. Please feel free to contact us and discuss your needs.

A complete listing of engine specifications and component parts can be found in the price sheet.



View our special edition "Who's Next" engine on page 24

**Great look!**  
Six shooter induction for all Indy engines



**605 Street Legend**

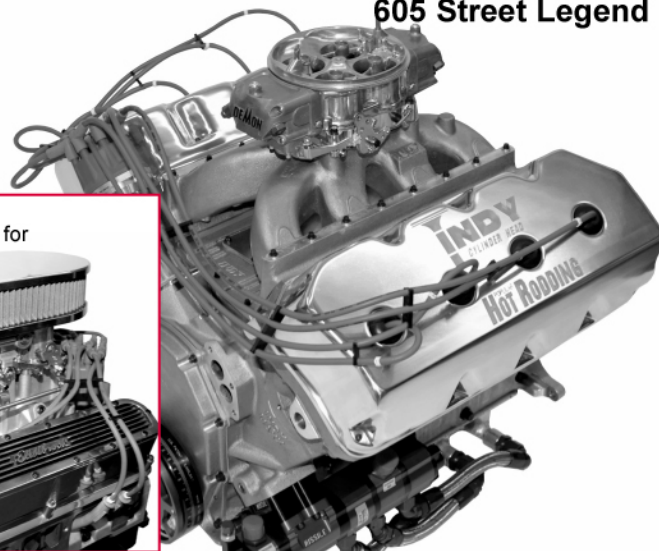

**Upgrades and options on engines are available.**  
See page 4 of the price sheet

## See page 3 of the price sheet for complete engine specifications

Legend Engine	Part #	Horsepower	Torque	Fuel
426"-438" Street Legend	426-C6-426-540	540 @ 6000 RPM	500 @ 4400 RPM	Pump
477"-485" Street Legend	426-C6-426-600	600 @ 6200 RPM	540 @ 4500 RPM	Pump
528" Street Legend	426-C6-528-650	650 @ 6300 RPM	630 @ 4700 RPM	Pump
528" All Aluminum Street Legend	426-C6-528-730	730 @ 6600 RPM	660 @ 4800 RPM	Pump
528" Super Charged Street legend	426-C6-528-950	950 @ 6800 RPM	890 @ 5000 RPM	Pump / Race
572" Race Legend	426-C6-572-960	960 @ 7400 RPM	760 @ 5900 RPM	Race
605" Street Legend	426-C6-605-830	830 @ 6700 RPM	780 @ 5000 RPM	Pump
605" Aluminum Race Legend	426-C6-605-1000	1000 @ 7400 RPM	840 @ 5700 RPM	Race
636" Race Legend	426-C6-636-1120	1120 @ 7400 RPM	930 @ 5800 RPM	Race

Small Block	Part #	Horsepower	Torque	Fuel
408-415" A Street Wedge	360-C6-408-420	420 @ 5400 RPM	450 @ 3400 RPM	Pump
408-415" A Street Master	360-C6-408-450	470 @ 5400 RPM	475 @ 3500 RPM	Pump
415" A Bracket Master	360-C6-415-650	650 @ 7200 RPM	530 @ 5500 RPM	Race
440" A Bracket Master	360-C6-440-680	680 @ 7200 RPM	590 @ 5600 RPM	Race
472" A Bracket Master	360-C6-472-700	700 @ 7200 RPM	600 @ 5600 RPM	Race

## AMC Crate Engines

Based on the 360 and the 401

Engine	Part #	Horsepower	Torque	Fuel
370" AMC Street Master	401-C6-370-360	360 @ 5200 RPM	390 @ 3800 RPM	Pump
407" AMC Street Master	401-C6-407-500	500 @ 6300 RPM	480 @ 4500 RPM	Pump
500"-512" AMC Bracket Master	401-C6-500-512	840 @ 7400 RPM	700 @ 5800 RPM	Race

Hemi is a trademark of Chrysler corporation used for identification purposes only

# Short Block Kits



## Balanced Rotating Assembly and Finish Machined Block

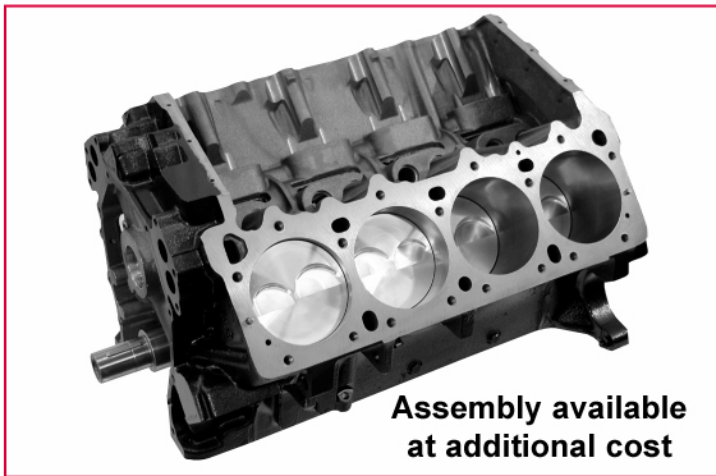

Assembly available at additional cost

### Short Block Kits

For the do it yourself enthusiast we offer Indy short blocks as kits. These kits are designed with everything you need to assemble a high quality, powerful Indy Engine. Kits include fully machined blocks, crankshaft, rods, pistons, pins, rings, rods and main bearings. Balanced.

Complete short block specifications and available upgrades can be found on page 5 of the price sheet.

**See page 5 of the price sheet for complete short block specifications**

### 360 Small Blocks

Short Block Kit	Part Number	Included Components
408-415" A Engine	360-S7-408A	Fully machined stock 360 block(408: 4.030" bore / 415: 4.060" bore) Eagle cast crank(4.00" stroke), Eagle I-Beam rods(6.123" x .984" pin), Pro-Tru dish pistons, rings, rods and main bearings, balanced. Dish pistons: 10.25 to 1 w/ 64cc and 9.5 to 1 w/ 68cc. Flat top: 12 to 1 w/ 64cc and 11.25 to 1 w/ 68cc
440" A Engine with Resto Siamese Block	360-S7-440A	Fully machined Mopar resto siamese block(4.185" bore) Eagle steel crank (4.00" stroke with 3.40 mains), Eagle H-Beam rods(6.123" x .984" pin), forged FT pistons, rings, rods and main bearings, internal balanced. FT pistons: 12.3 to 1 w/ 64cc
472" A Engine with Resto Siamese Block	360-S7-472A	Fully machined Mopar resto siamese block(4.200" bore) Callies 4340 steel crank(4.250 / 2.100-340 mains), Eagle H-Beam rods(6.250 / .927" pins), Forged flat top pistons, rings, rod and main bearings, internal balanced 13 to 1 with 64cc. Available with dish pistons 10.00 to 1 with 64cc.

### 440 Wedge B/RB Blocks

Short Block Kit	Part Number	Included Components
500-528" Wedge with Indy Maxx Aluminum B Block	440-S7-500A	9.98" deck height. Indy Maxx aluminum block(500": 4.375" bore / 528":4.500" bore), Eagle 4340 steel crank(4.150" x 2.375") Eagle 3D H-Beam rods(6.760" x .990" pins) Wiseco flat top pistons, rings, rod and main bearings, balanced. 500" flat top pistons: 12.5 to 1 with 75cc and 13.9 to 1 with 65cc
500" Wedge	440-S7-500W	MP siamese mega block(4.375" bore) (CNC lightened, bored, decked and stroke clearanced)Eagle 4340 steel crank(4.150" x 2.375") Eagle 3D H-Beam rods(6.760" x .990" pin) Wiseco flat top pistons, Rings, rod and main bearings, balanced. Flat top piston: 12.5 to 1 w/ 75cc and 13.9 to 1 w/ 65cc
528" Wedge	440-S7-528W	MP siamese mega block(4.500" bore) (CNC lightened, bored, decked and stroke clearanced)Eagle 4340 steel crank(4.150" x 2.375") BME aluminum rods (7.150" x .990" pin) Wiseco flat top pistons, Rings, rod and main bearings, balanced. Flat top piston: 13 to 1 w/ 75cc and 14.25 to 1 w/ 65cc
540" Wedge with aluminum B block	440-S7-540BW	9.98 deck height Indy Maxx aluminum block (4.500" bore) Callies 4340 steel crank (4.250 / 2.2 Chevy width) Eagle 3D H-Beam rods (6.535 / .990) Wiseco flat top pistons, rings, rods and main bearings. Internal balanced 13.00 with 75cc and 14.3 with 65cc
540-572" Wedge	440-S7-540W	MP siamese mega block(540:4.375" bore) (CNC lightened, bored, decked and stroke clearanced)Callies 4340 steel crank(4.5" x 2.200") BME aluminum rods(7.150" x .990" pin) Wiseco flat top pistons, Rings, rod and main bearings, balanced. 540 Flat top piston: 13 to 1 w/ 75cc and 14.3 to 1 w/ 65cc
605" Street Wedge	440-S7-605W	MP siamese mega block(4.500" bore) (CNC lightened, bored, decked and stroke clearanced)Callies 4340 steel crank(4.75" x 2.200") Eagle 3D H-Beam rods(7.100" x .990" pin) Wiseco flat top pistons, Rings, rod and main bearings, balanced. Flat top piston: 10.75 to 1 w/ 75cc
655" Big Wedge	440-S7-655W	Indy Maxx aluminum block(4.563"), Callies 4340 steel crank(5.00" x .990" pin), Wiseco flat top pistons, Rings, rods and main bearings. Balanced. Flat top piston: 16.0 to 1 with 65cc. 55mm roller cam bearings installed.



### Build your own engine

Have you ever wanted to build your own engine? Well **this is your chance**. We have everything that you will need to get the job done. Order a short block kit from us and all the other necessary engine parts to build your engine to your own specifications. We've got short blocks, manifolds, carburetors, EFI, oil systems and anything else you need.



Hemi is a trademark of Chrysler corporation used for identification purposes only



# Short Block Kits

Balanced Rotating Assembly and Finish Machined Block

New 6.1 Short Block

We have many upgrades available for our short block kits.

We also have short blocks for the new 5.7 or 6.1 Hemi. See page 21 of this catalog or page 14 of the price guide

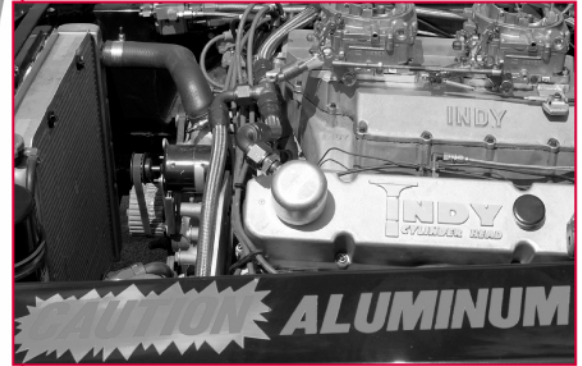
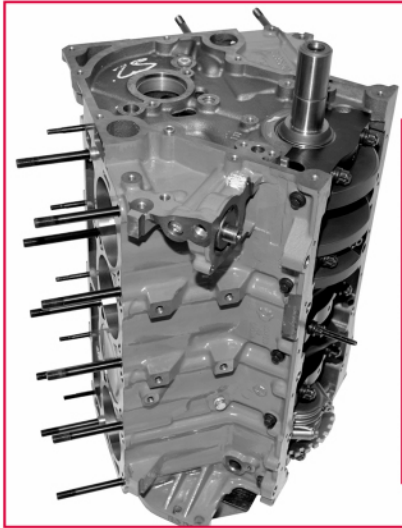

## 426 Hemi

Short Block Kit	Part Number	Included Components
426-472-528-540" Hemi	426-S7-426H	MP Block(426" Water 4.250"528" Siamese 4.500" bore) Eagle 4340 steel crank (4.150" x 2.375") Eagle 3D H-Beam rods (6.860" x 1.031" pins), Wiseco dome pistons, Rings, rods and main bearings. Balanced. Dome pistons 10.25 to 1 with 170cc Available in kit form only.
572-605" Legend Hemi (Race)	426-S7-572H	MP mega block (4.500" bore) (CNC lightened, bored, decked and stroke clearanced). Callies 4340 steel crank (4.150" x 2.2" or 2.375"), BME aluminum rods (7.150" x .990" pins), Wiseco flat top pistons, rings, rod and main bearings, balanced, dome pistons:14.5 to 1 with 170cc, 15 to 1 with 166cc
605" Legend Hemi (Street)	426-S7-572H	MP siamese mega block(4.500" bore) ( CNC lightened, bored, decked and stroke clearanced), Callies 4340 steel crank (4.750" x 2.200"), Eagle 3D H Beam rods (7.100" x .990" pin), Wiseco dome pistons, File fit rings, rod and main bearings, balanced. Dome pistons: 10.75 to 1 with 170cc
636" Legend Hemi (Race)	426-S7-636H	Indy maxx aluminum block, raised cam, wide pan rails, (4.500" bore) CNC, bored, decked and stroke clearanced. Callies 4340 crank (5.00" x 2.200"), GRP aluminum rods (6.950" x .990" pin), Wiseco dome pistons, rings, rods and main bearings. balanced, 16:1 with 166cc

See page 5 of the price sheet for complete short block specifications

Questions: Call us with any questions you may have about ordering your short block kit. We have experienced technicians ready to answer your technical questions.

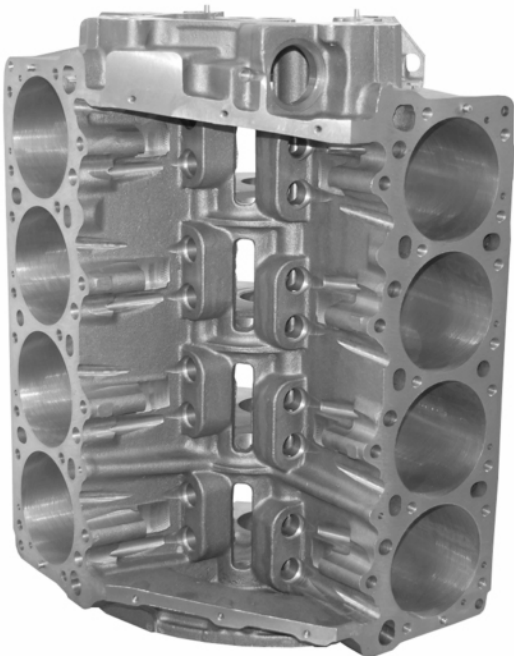

Hemi is a trademark of Chrysler corporation used for identification purposes only



# Rotating Assemblies



Crank, rods, pistons, pins, locks, rod and main bearings



## Rotating Assemblies

No one can put together a finer rotating assembly than Indy Cylinder Head. Our years of experience and testing allows us to assemble just the right combination of components to generate real horsepower. The quality of the components used in our rotating kits is unsurpassed assuring you of an engine build that will be done right the first time.

**See page 6 of the price sheet for complete assembly specifications**

360 Small block	Part Number	Included Components
408-415" 360 Small Block	360-R6-408A	Eagle cast crank (4.00" stroke), Eagle SIR rods, No block clearance necessary. Wiseco flat top dish or pistons, rings, rod and main bearings,
440" Small Block	360-R6-440A	Eagle steel crank (4.00" stroke, 340 mains), Eagle H-Beam rods (6.123" x .984" pins), Wiseco flat top pistons (4.185" bore), rings, rods and main bearings
472" Small Block	360-R6-472A	Callies 4340 steel crank (4.250" / 2.100" - 340 mains) Eagle H-Beam rods (6.250" / .927") Wiseco flat top pistons, piston rings, rod and main bearings.

## 440 Wedge B/RB

426" 400 Block	400-R6-426A	Indy steel crank (3.530" x 2.2" pins) Eagle 3D-H-Beam rods (6.385" x .990" pins), Wiseco flat top pistons (4.380" bore), rings, rods and main bearings, flat top pistons (10.25 to 1 with 75cc)
470" 400 Block	400-R6-470A	Eagle 4340 steel crank (3.900" x 2.2" pins), Eagle 3D H-Beam rods (6.385" x .990" pin), Wiseco flat top pistons (4.375" bore), rings, rods and main bearings, flat top pistons: 11.75 to 1 w/ 65cc 13 to 1 w/ 65cc
500" 400 Block	400-R6-500A	Eagle 4340 steel crank (4.150" x 2.375" pin) Eagle 3D H-Beam rods (6.760" x .990" pins), Wiseco flat top pistons (4.375" bore), rings, rods and main bearings, Flat top pistons: 12.5 to 1 w/ 75cc
540" 400 Maxx Block	400-R6-540A	Callies 4340 steel crank (4.250" / 2.2 Chevy width) Eagle H-Beam rods (6.535" / .990") Wiseco flat top pistons (4.500" bore) rings, rod and main bearings. 13 to 1 with 75cc, 14.3 to 1 with 65cc
451" 440 Block	440-R6-451B	Eagle 4340 steel crank (3.750" x 2.375" pin) Eagle 3D H-Beam rods (6.760" x .990" pins), Wiseco flat top or dome pistons (4.375" bore), rods, rings and main bearings, Flat top pistons: 11.25 to 1 w/ 75cc, 12.5 to 1 w/ 65cc Dome pistons: 12.5 to 1 w/ 75cc and 14 to 1 w/ 65cc
500" 440 Block	440-R6-500A	Eagle 4340 steel crank (4.150" x 2.375" pin) Eagle 3D H-Beam rods (6.760" x .990" pins), Wiseco flat top pistons (4.375" bore), rings, rods and main bearings, Flat top pistons: 12.5 to 1 w/ 75cc, 13.9 to 1 w/ 65cc
528" 440 Block	440-R6-540B	Eagle 4340 steel crank (4.150" x 2.375" pin) BME aluminum rods (7.150" x .990" pins), Wiseco flat top pistons (4.500" bore), rings, rods and main bearings, Flat top pistons: 13 to 1 w/ 75cc and 14.25 to 1 w/ 65cc
540" Econo 440 Block	440-R6-540A	Eagle 4340 steel crank (4.500" x 2.2 pin) Eagle H Beam rods (7.1000" x .990" pins), Wiseco flat top pistons (4.375" bore), rings, rods and main bearings, Flat top pistons: 13 to 1 w/ 75cc and 14.3 to 1 w/ 65cc
540-572" 440 Block with Aluminum Rods	440-R6-540B	Callies 4340 steel crank (4.500" x 2.2" or 2.375" pin), BME aluminum rods (7.150" x .990" pins), Wiseco flat top pistons (540: 4.375" bore / 572": 4.500" bore), rings, rods and main bearings, 540 Flat top pistons 13 to 1 w/ 75cc, 14.3 to 1 w/ 65cc. 572: 13.6 to 1 w/ 75cc, 15 to 1 w/ 65cc
557-588" 440 Block with Steel Rods	440-R6-557B	Callies 4340 steel crank (4.625" x 2.2"), Eagle 3D-Hbeam rods (7.100" x .990" pins), Wiseco flat top pistons (557: 4.375" bore / 588": 4.500" bore), rings, rods and main bearings, 557" Flat top pistons: 13.25 to 1 w/ 75cc, 14.55 to 1 w/ 65cc. 588" flat top: 13.85 to 1 w/ 75cc, 15.25 to 1 w/ 65cc
655" Big Wedge	440-R6-426H	Callies 4340 steel crank (655 5.000" x 2.2"), GRP aluminum rods (655: 6.950" x .990" pins), Wiseco flat top pistons (4.563" bore), rings, rods and main bearings, 655" flat top pistons: 16 to 1 with 65cc. Tool steel pins included

## 426 Hemi

426" - 485" Legend Hemi (Street)	426-R6-426H	Eagle 4340 steel crank (3.750" x 2.375" pin), Eagle 3D-H Beam rods (6.860" x 1.031" pins), forged dome pistons (4.250" bore), rings, rod and main bearings, Dome pistons: 10.25 to 1 with 170cc
528" Legend Hemi (Street)	426-R6-528H	Eagle 4340 steel crank (4.150" x 2.375" pin), Eagle 3D-H Beam rods (6.860" x 1.031" pins), Wiseco dome pistons (4.500" bore), rings, rod and main bearings, Dome piston: 10.25 to 1 w/ 170cc
605" Legend Hemi (Street)	426-R6-605H	Callies 4340 steel crank (4.750" x 2.2" pin), Eagle 3D-H Beam rods (7.100" x .990" pins), Wiseco dome pistons (4.500" bore), rings, rod and main bearings, Dome piston: 10.75 to 1 w/ 170cc
572-636" Legend Hemi (Race)	426-R6-636H	Callies 4340 steel crank (572: 4.500" x 2.2 / 636": 5.00" x 2.2), BME Aluminum rods (572: 7.150" x .990 pins / 636: 6.950" x .990" pins), Wiseco dome pistons (4.500" bore), rings, rod and main bearings, 572" Dome piston: 14.5 to 1 w/ 170cc / 636" Dome pistons 16 to 1 w/ 166cc

Hemi is a trademark of Chrysler corporation used for identification purposes only



# Engine Blocks

## Maxx, Mopar and Stock Blocks

### Engine Blocks

Don't waste your time and money on used or questionable blocks. Get the best available Chrysler blocks from Indy Cylinder Head. Our years of experience with precision machining allows us to provide engine blocks of uncompromised quality and performance.

***You just can't go wrong!***

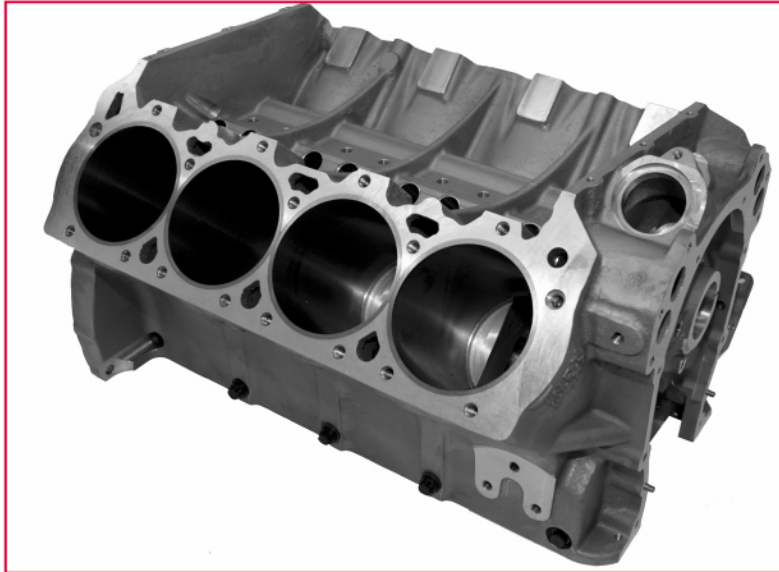

**See page 7 of the price sheet for specifications and prices**

### Indy Maxx Aluminum B, RB or Hemi Water Blocks

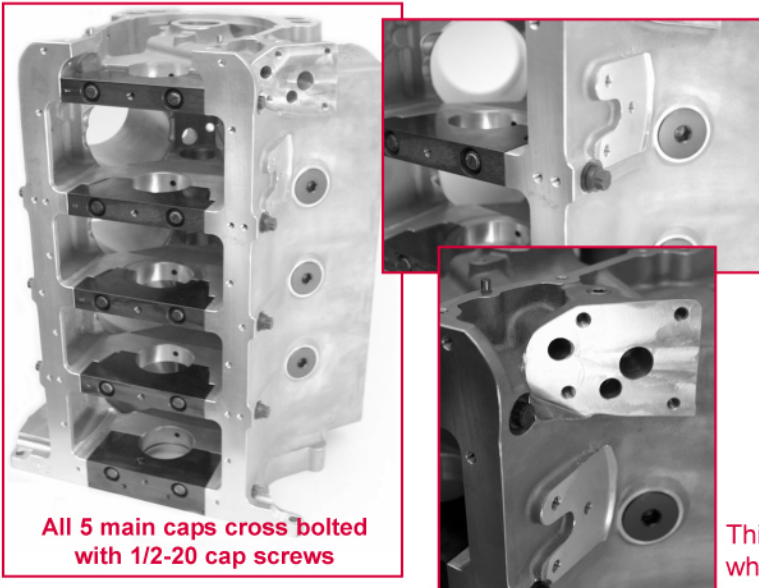

All 5 main caps cross bolted with 1/2-20 cap screws

Indy Maxx aluminum blocks are the finest water jacketed blocks in the industry. These blocks easily handle high horsepower loads with reliability that's second to none. All our Indy Maxx water blocks include: choice of sleeves, cam bearings and screw in core plugs installed, dowels and oil gallery plugs supplied, Steel billet main caps, all 5 main caps cross bolted, siamese dry sleeve construction, .300" between cylinders at 4.500" bore, finished line hone, finished lifter bores, standard oil pan bolt pattern, available wide oil pan bolt pattern. Machined aluminum block ( 4.500" bore) weighs **133 lbs.**

**440-B4-MWB** 440 RB Wedge Indy Maxx aluminum block (9.980 or 10.720)

**426-B4-MWB** 426 Hemi Indy Maxx aluminum water block (9.980 or 10.720)

This block removes 110 lbs from the front of the car while supplying superior strength and reliability

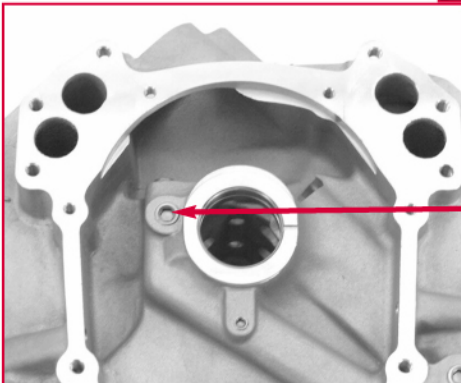

Isolated main oil galley prevents oil pressure leakage around lifters

3 rib valley for added strength

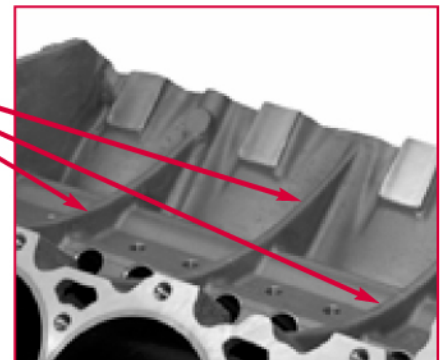

Removes 110 lbs off the front of the car

Hemi is a trademark of Chrysler corporation used for identification purposes only

# Engine Blocks



## Indy Maxx Aluminum Solid Blocks

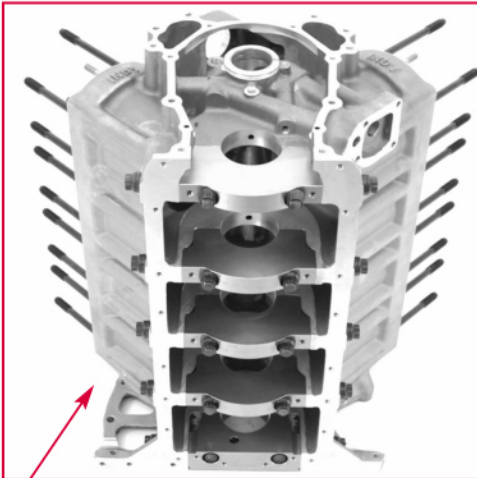

Maxx aluminum solid block showing aluminum billet main caps with all 5 caps cross bolted with 1/2-20 cap screws

Reinforced bellhousing area

The Indy Maxx solid block has extra strength added deck and valley area and features superior rear valley drain backs.

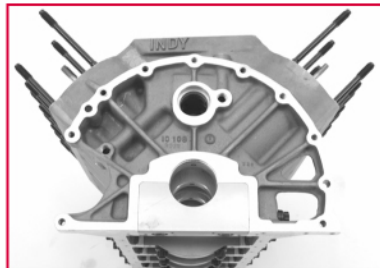

**426-B4-MSB** 426 Hemi Indy Maxx aluminum solid block (9.980 or 10.720)



## Indy IC401 AMC Aluminum Water Block

Our IC-401 AMC Bare water block includes:

Your choice of sleeves, cam bearings and screw in core plugs installed, dowels and oil gallery plugs supplied, splayed steel billet main caps, std. bell housing and front cover, siamese dry sleeve construction, 6 1/2 x 13 head bolts per cylinder, finished line hone, finished lifter bores, std oil pan bolt pattern, redesigned oil system, 4.375" machined aluminum block weighs 115 lbs.  
**401-B4-MWB AMC** Indy Maxx aluminum bare water block (9.200 to 9.400)

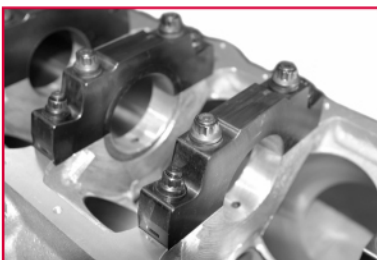

Billet steel splayed bolt center main caps, ARP 1/2" main studs with 7/16" outside splayed studs and 12 pt nuts. All main caps are doweled to block to eliminate cap walk. Uses std AMC main bearings

See page 7 of the price sheet for labor upgrades and parts

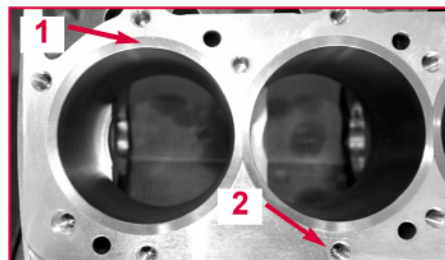

IC 401 features include:

- (1) Big bore standard (4.375") with interlocking Hi nickel ductile sleeves
- (2) Five 1/2 x 13 head bolts per cylinder. Five standard and one lower outside 7/16 x 14 head bolts added for new Indy heads.

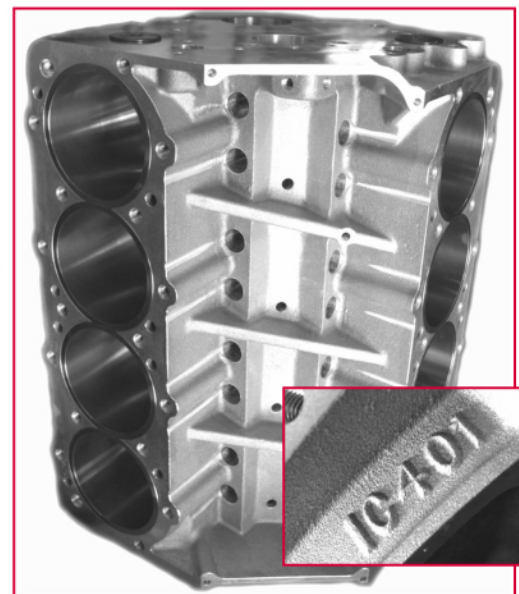

The Indy IC401 block is capable of supporting high horsepower due to the changes we have made: Billet steel splayed bolt main caps, valley cross braces, improved head bolt clamping, interlocking Hi nickel ductile dry sleeve construction and **improved oiling**.

The IC-401 weighs 115 lbs with 4.375" bore and 9.400" tall deck

Hemi is a trademark of Chrysler corporation used for identification purposes only



# Engine Blocks

## Mopar Performance and Indy Stock Blocks

### Mopar Siamese or Water Cast Iron 340, 440, 426 and 6.1 Blocks

Indy Cylinder Head offers these blocks fully machined and blue printed. All blocks include: cam bearings, dowels and plugs installed. CNC bored located off deck dowels. Square deck with BHJ fixture, torque plate honed, finish honed, line hone finish, CNC stroke cleared for 4.625" stroke, CNC lightening outside of block ( Wedge and Hemi).

#### Indy CNC machined Mopar blocks:

340 Resto Water Block	340-B4-RWB
340 Resto Siamese Block	340-B4-RSB
440 Wedge Water Mega Block	440-B4-WWB
440 Wedge Siamese Mega Block	440-B4-HWB
426 Hemi Water mega Block	426-B4-HWB
426 Hemi Siamese mega Block	426-B4-HSB
6.1 hemi Water Block	6.1-B4-HWB

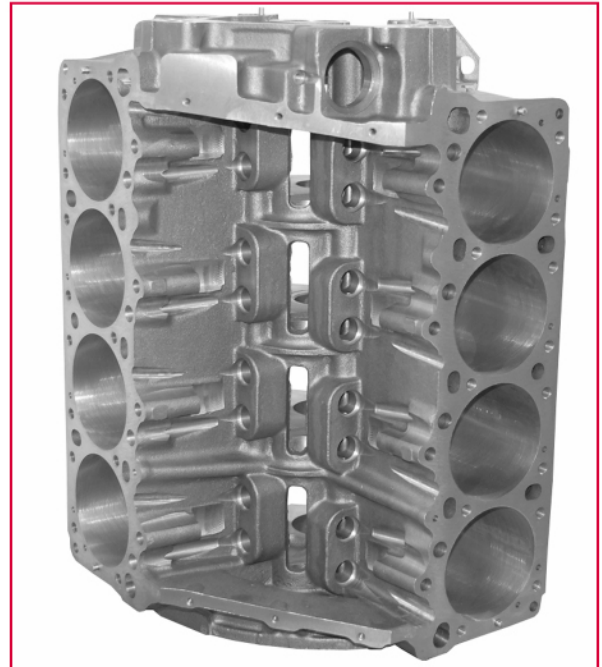

The standard CNC lightened block has the motor mounts removed

**Call for pricing on labor upgrades and additional parts**

**See page 7 of the price sheet for specifications and prices**

### Indy stock street cast iron 360, 400 and 440 Blocks

360 Block

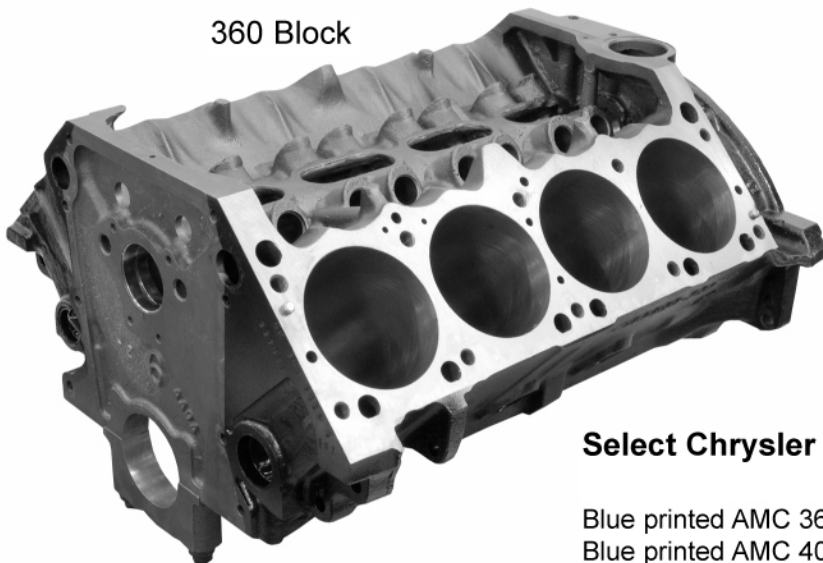

Select Chrysler or AMC bare stock blocks fully machined and blue printed include: Oven baked and shot blasted, line honed with new ARP main bolts, cam bearings and plugs installed, square deck with BHJ fixture, magnafluxed and pressure tested, bore and plate honed on Sunnen CK 616 diamond hone.

#### Select Chrysler or AMC blocks:

Blue printed AMC 360 bare stock block	401-B4-SB3
Blue printed AMC 401 bare stock block	401-B4-SB4
Blue printed Chrysler 360 A engine bare stock block	360-B4-SB
Blue printed Chrysler 400 Bare stock blocks	400-B4-SB
Blue printed Chrysler 440 Bare stock blocks	440-B4-SB

400 and 440 blocks are available with an upgrade to aluminum main caps

Hemi is a trademark of Chrysler corporation used for identification purposes only

# Indy Neon Parts



Power up your Neon with an Indy engine that really gets it done. Our years of engine experience with the eight cylinder power plants has helped us design and build the top of the line four cylinder performer.

**Neon Engine 3.465" 2.2L (134 cid)**

Indy Neon engines are fully assembled, dyno tested and tuned. Each engine includes the following components:

- Fully prepped stock 2.0 block
- Callies 3.543" crankshaft
- IN-29 Eagle H-beam rods (5.472")
- IN-25 Wiseco pistons 10.50 to 1
- IN-DAS head (36mm x 31.5mm)
- Crane #12 cams
- Crane cam gears
- IN-5 fully ported
- Moroso baffled oil pan Melling pump
- 2.4 adjusters and rockers
- ARP head studs
- Intake rotating assembly balanced # NE0-C6-2.2L

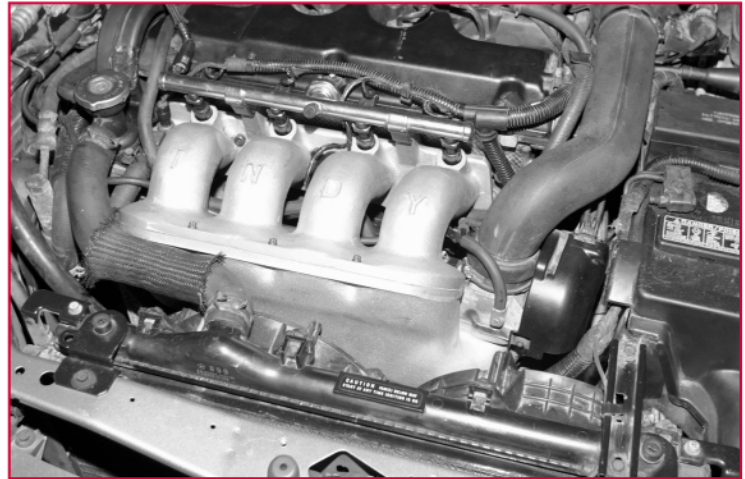

Order all the parts to build your own engine: Machining of supplied block, balanced rotating assembly, head assembly and port work on heads. #NE0-C6-2.2L-1

**See page 8 of the price sheet for complete engine specifications**

## Other Neon Parts

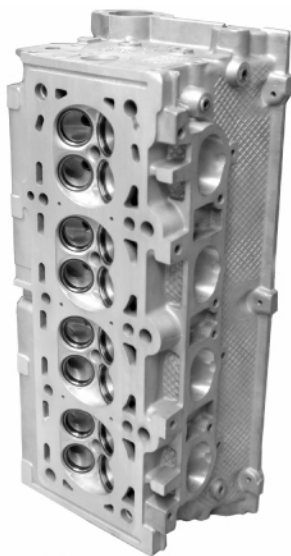

**DOHC CNC Head**

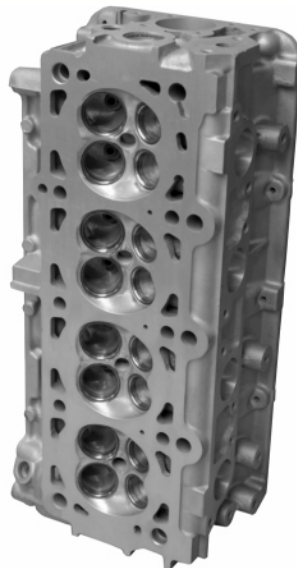

**SOHC CNC Head**



**Stroker Kit**

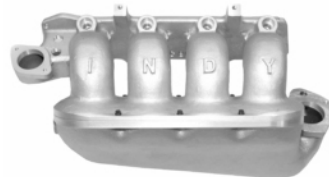

**DOHC Manifold**

## Other Neon Parts

### Head and Intake kit

Neon 2.0 4 cyl. 95-99  
Single or double cylinder head and manifold kit:  
IN-1SAs or IN DAS head  
IN-5 or IN-6 Intake manifold  
Port match Indy intake  
**NEO-H1-1K**

### Single Overhead Cylinder Heads Bare

Fully ported OEM casting  
3 angle valve job  
Stock diameter valve job  
Fully 100% CNC ported  
273 cfm intake flow  
fully inspected  
Flat milled  
Ready to assemble  
**NEO-H1-1S**

### Assembled CNC ported SOHC head

Stock diameter ss valves  
Titanium retainers  
New locks  
New valve springs. seals  
Cleaned and assembled  
**NEO-H1-1SAS**

### Double Overhead Cylinder Heads Bare

Fully ported OEM casting  
3 angle valve job  
Stock diameter valve job  
Fully 100% CNC ported  
315 cfm intake flow  
fully inspected  
Flat milled  
Ready to assemble  
**NEO-H1-1D**

### Neon 2.2 Stroker Kit

Callies forged 3.54 stroke  
Forged pistons .827 pins  
Hastings ring pack  
3.465" bore  
IN-29 Eagle H Beam rods  
IN-30/31 main and rod bearings  
**NE0-R6-34**

### Assembled CNC ported DOHC head

Stock diameter ss valves  
Titanium retainers  
New locks  
New valve springs. seals  
Cleaned and assembled  
**NEO-H1-1DAS**

See page 8 of the price sheet for a complete parts list



# CNC Cylinder Head Porting

## Windjammer CNC porting

We offer our complete line of cylinder heads 100% CNC ported. Our years of porting experience allows us to replicate ports and chambers from one head to another. This provides us with the ability to match port volumes and flow resulting in great flow numbers and higher horsepower for you.



The key to high horsepower is **port volume**. Larger cubic inch engines require larger volume ports. We have not only created the highest quality CNC heads, but we have also developed heads with a wide range of port volumes to provide you with the correct heads for your horsepower needs.

We offer CNC heads for Chrysler small blocks, Hemi, big blocks, Wedge engines, AMC 401 and the new 5.7 or 6.1L Hemi engines. Complete specifications, applications, flow rates and C.I.D. displacements can be found on page 9 of the price sheet. Please feel free to call us with any questions.

**See page 9 of the price sheet for complete specifications and prices**

## Here's just a few of the CNC heads we offer



**440-1 CNC-325**

**Bolt on  
instant  
horsepower  
gain**

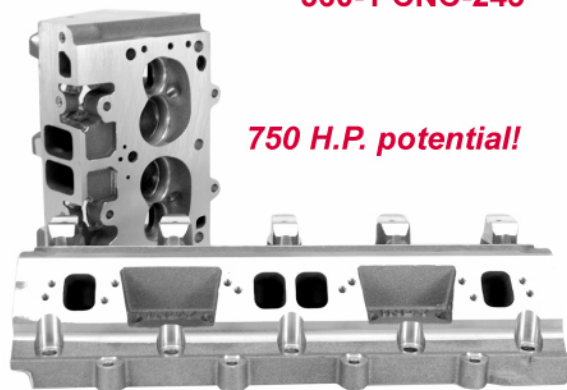

**360-1 CNC-245**

**750 H.P. potential!**

**440-1 CNC-325 for Wedge or Big Block**  
325 cc intake volume. 375 cfm flow. 470"-500" C.I.D.  
Great head for pro street or drag racing. Pro street solid combinations and drag race roller combinations. Works well with 12.5 to 1 compressions and up. **850 HP potential**

**360-1 CNC-245 for Small Block**  
245 cc intake volume. 330 cfm flow. 390"-440" C.I.D.  
Great for any street or bracket race combinations. Works well with 11 to 1 and up compression and pump or race gas. Preferred head for large CID engines

Here's a list of the CNC heads we offer. Last number referenced is the intake port volume

### Wedge Big Block

440-EZ CNC-295    440-EZ CNC-325  
440-SR CNC-295    440-1 CNC-325  
440-1 CNC-345

572-13 CNC-365    572-13 CNC-385

600-13x CNC-460

### Legend Hemi

426-1 CNC-285  
426-1RA CNC-295  
426-1R CNC-285  
426-1RA6 CNC-325

### Small Block

360-2 CNC-230 Oval port  
360-1 CNC-245 Rect port

### 5.7 Hemi

CNC-184

### 401

AMC CNC-275  
AMC CNC-300

### 6.1 Hemi

CNC-216

Hemi is a trademark of Chrysler corporation used for identification purposes only

# CNC Cylinder Head Porting

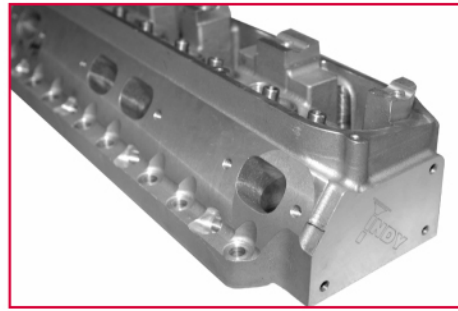
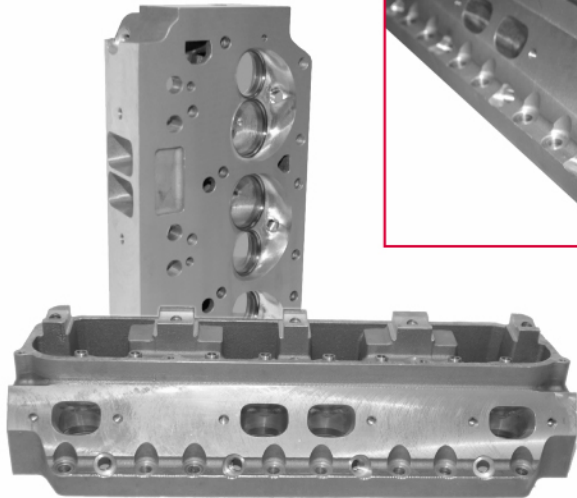

*We utilize cutting edge technology in the CNC process to provide our customers with the best possible CNC port available.*

*We provide great tech advice and fast shipping*

440-EZ CNC-295	Wedge Big Block 383" - 500"	Named the " <b>Little Easy</b> " this head is designed for A body cars with stock exhaust port location and bolt pattern. Most standard exhaust headers will work. Stock push rod location with Maxx Wedge intake size opening.
440-EZ CNC-325	Wedge Big Block 440" - 540"	The " <b>Big Easy</b> " head is designed for A body cars with bigger cubic inch Wedge engines with stock exhaust port location and bolt pattern. Most standard exhaust headers will work with offset intake push rod location for larger intake runner. Offset intake rocker arms needed.

**See page 9 of the price sheet for complete specifications and prices**

440-SR CNC-295	Wedge Big Block 393" - 500"	Any <b>street or bracket race</b> combo. Cylinder head has Maxx Wedge port opening to utilize Indy Maxx Wedge manifolds. Perfect head for 10:1 compression and up engines. Solid or rocker cam combinations. Huge improvement for any basic bracket engine. 2.19 x 1.81 valve size.
440-1 CNC-325	Wedge Big Block 470" - 500"	Great head for <b>pro street to drag race</b> . Pro street solid combinations and drag race roller combinations. Works well with 12.5 to 1 and up compressions. 850 HP potential. 2.19 x 1.81 valve size.
440-1 CNC-345	Wedge Big Block 500" - 540"	Recommended 4.375" bore. <b>Drag race</b> application. Roller cam combinations preferred. Works well with 12.5 to 1 compression and up. Perfect head for pro street supercharger applications. 900 HP potential. 2.25 x 1.81 valve size.
572-13 CNC-365	Wedge Big Block 528" - 572"	4.375" bore minimum. <b>Drag race</b> applications. Roller cam combinations preferred. Works well with 13.5 to 1 and up compressions. Most use Jessel rocker arm systems. Perfect for any 528 / 4.500" bore Wedge engine. 2.300 x 1.88
572-13 CNC-385	Wedge Big Block 572" - 605"	Recommended 4.500" bore minimum. <b>Drag race</b> applications. Works well with 13.5 to 1 and up compressions. Must use Jessel rocker arm system. 2.300 x 1.88 valve size.
600-13X CNC-460	Wedge Big Block 605" - 655"	Recommended 4.840" bore center block (Indy Maxx block). Good for 655". Works well with 14.5 to 1 and up compressions. Must use Jessel rocker arm system on head. 2.450 x 1.810 valve size. 1200 HP

Hemi is a trademark of Chrysler corporation used for identification purposes only



# CNC Cylinder Head Porting

It all started with cylinder head porting. We have over 35 years of experience with proven results at the strip. Call us and we'll answer any questions you may have.

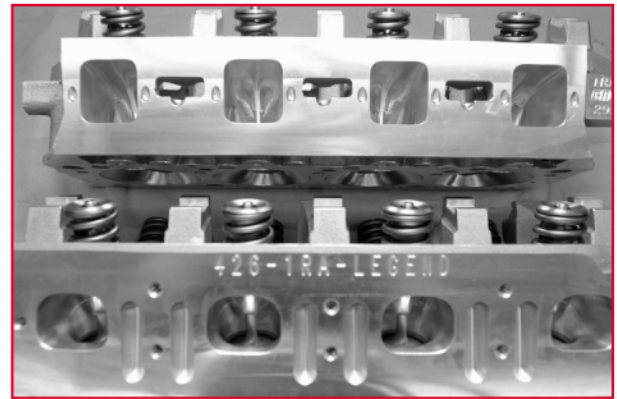
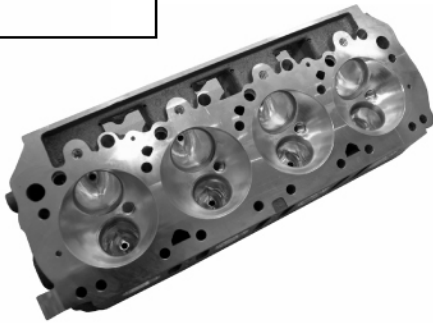

426-1 CNC-285	Legend Hemi 426" - 528"	Any <b>street or bracket race</b> combo. 16 bolt intake pattern with raised exhaust ports. Works well with 10.75 to 1 and up compression. Preferred head on smaller CID race engines and larger CID street engines. Perfect head for 605 street engine. Good head for supercharged pro street combinations. Headers available. 2.250 x 1.94 valve size.
426-1RA CNC-295	Legend Hemi 528" - 605"	Any <b>street or bracket race</b> combo. 16 bolt intake pattern with raised exhaust ports. Works well with 10.75 to 1 and up compression. Preferred head on smaller CID race engines and larger CID street engines. Good head for supercharged pro street combinations. Headers are available. 2.400 x 1.94 valve size
426-1RA6 CNC-325	Legend Hemi 572" - 636"	Great head for <b>drag race</b> applications with large lift roller cam combinations. 10 bolt intake bolt pattern with raised exhaust ports. Works well with 14.5 to 1 compression. 1200 HP potential cylinder head. Indy tunnel ram manifold(426-5) preferred manifold. 2.400 x 1.94 valve size
360-2 CNC 230	Oval port small block 370" - 426"	Any <b>pro street</b> or <b>drag race</b> combination. Cylinder head has W-2 style intake flange, W-2 standard exhaust flange and utilizes Indy rocker arms. Works well with 10:1 compression and up. Preferred head for street or race stroker engines. 650+ HP potential. 2.100 x 1.65 valve size.
360-1 CNC 245	Rectangular port small block 390" - 440"	Any <b>street</b> or <b>bracket race</b> combinations. Cylinder head has W-2 style intake flange, W-2 or standard exhaust flange and uses Indy rocker arms. Works well with 11 to 1 and up compression. Pump or race gas. Preferred head for CID race engines and largeCID street engines. 2.140 x 1.650 valve size.
401-1 CNC-275	AMC 401" - 500"	Recommended 4.200 bore minimum. Must use Indy intake or sheet metal and 440 exhaust flanges. Has additional 7/16 head bolt holes to utilize Indy 401-1 aluminum block. <b>Pro street</b> and <b>drag race</b> applications. Roller cam preferred. 2.190 x 1.81 valve size. Works on stock 401 block
401-1 CNC-300	AMC 443" - 500"	Recommended 4.375 bore minimum. Must use Indy intake or sheet metal and 440 exhaust flanges. Has additional 7/16 head bolt holes to utilize Indy 401-1 aluminum block. <b>Pro street</b> and <b>drag race</b> applications. Large lift roller cam preferred. 2.250 x 1.81 valve size
5.7 CNC-184	5.7 Hemi	By porting your 5.7 heads you can see gains of 55 HP and 45 ft lbs of torque. Put this head on a 392" engine and make 50 HP with minimal increase in gas mileage.
6.1 CNC-216	6.1 Hemi	By porting your 6.1 heads you can see gains of 55 HP and 45 ft lbs of torque. Put this head on a 426" engine and make 600 HP and 600 torque with minimal increase in gas mileage.

Hemi is a trademark of Chrysler corporation used for identification purposes only



# 401 AMC PARTS



## AMC Heads and Components

We carry the most extensive line of AMC engine parts anywhere!

### 401-1K AMC Aluminum Head Kit

*Everything between the carb and the block*

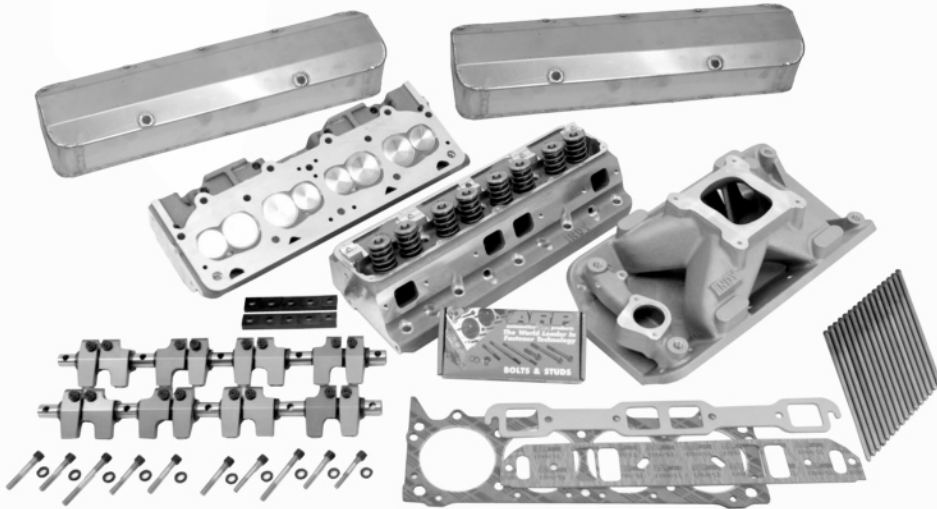

If you are looking for AMC parts we've got them!

We carry an extensive line of AMC components ranging from cylinder head kits down to head bolts.

- Aluminum head kits
- Indy aluminum bare heads
- Assembled heads
- Manifolds
- Complete rockers
- Valve covers
- Valves
- Head bolt kits
- E.F.I 401 Intakes
- Timing covers
- Billet oil pumps
- Timing cover assemblies

See page 10 of the price sheet for complete parts list and prices

### 401-3 Single Plane Intake

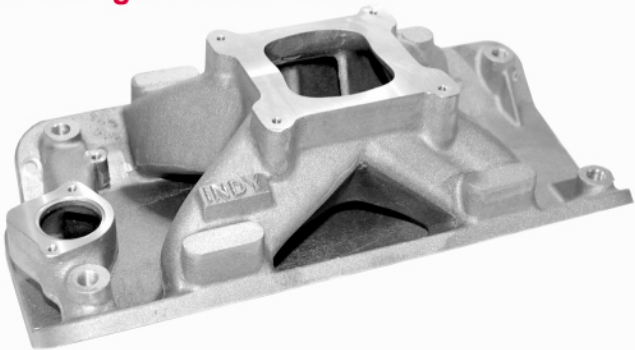

### 401 Assembled Heads with Manifold

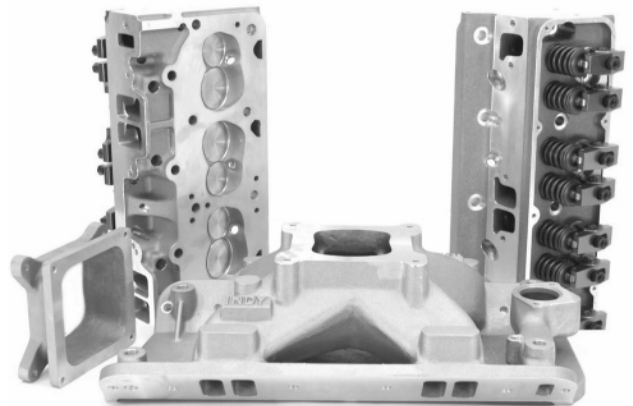

Oil Pan and Pick Up

AMC Front Cover with Billet Aluminum Oil Pump

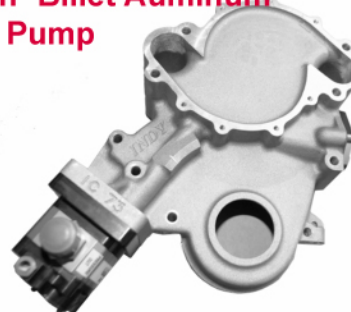

401 Rocker Arms



Hemi is a trademark of Chrysler corporation used for identification purposes only



# 360 Small Block Parts

## Small Block Cylinder Head Kits



### Indy Small Block Chrysler Aluminum Head Kit

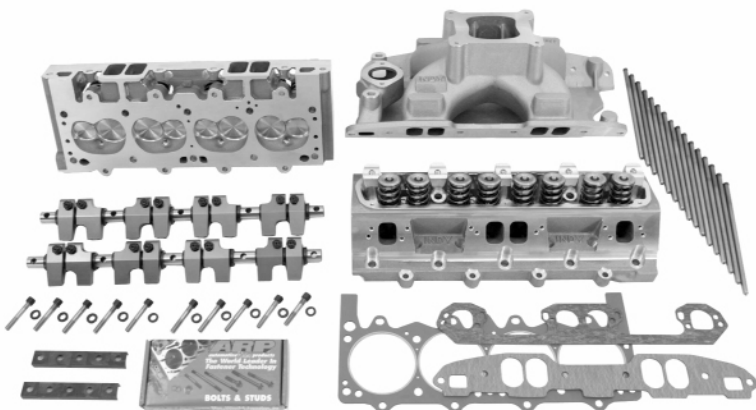

When we decided to make small block heads we used our proven format: light weight castings, long valves and the proper port volume. These heads work on a stock block and take advantage of the 18 bolt head bolt pattern found on the "R" series blocks from Mopar Performance.

These heads will transform your small block into a serious street machine or a very reliable, very powerful bracket engine.

Since 400"+ cid small blocks are common, our 360-1 rectangular port head was created to fill the bill perfectly.

#### 360-H1-1K small block head, rectangle port, 210cc ip

360-1AS head assembly 360-3R manifold 360-4 rock ass'y  
360-9 pushrod kit 360-16 head bolts 360-11 rocker shaft stud  
kit head gaskets intake/exhaust gaskets 63cc chamber

#### 360-H1-2K small block head, oval port, 180cc ip

360-1AS head assembly 360-3 manifold 360-4 rocker ass'y  
360-9 pushrod kit 360-16 head bolts 360-11 rocker shaft stud  
kit head gaskets intake/exhaust gaskets 63cc chamber

**See page 10 of the price sheet for complete parts list and prices**

### 360-A Engine Parts

If you are looking for small block 360-A parts we've got them!

We carry an extensive line of components ranging from cylinder head kits down to head bolts.

- Aluminum head kits
- Indy aluminum bare heads
- Assembled heads complete
- Manifolds
- Rockers- individual
- Complete rockers
- Rocker shaft clamps
- Pushrods
- Valve covers
- Valves
- Head bolt kits
- E.F.I. intake with fuel rails
- E.F.I. 360 small block complete systems

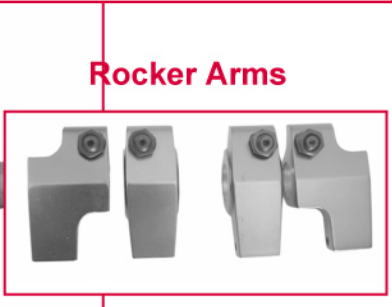
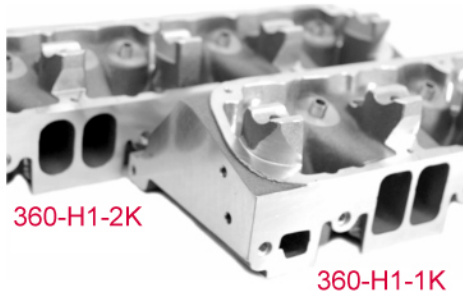

Hemi is a trademark of Chrysler corporation used for identification purposes only

# Indy Edelbrock Parts



In our continuing effort to serve the needs of the industry we manufacture a large selection of Indy Edelbrock parts ranging from small and big block cylinder head kits to manifolds, valves and head bolts. Please call us for additional information since we carry too many parts to list. The accompanying price guide has a full list of available parts with prices.

## Indy Edelbrock Cylinder Head Assemblies

Part Number	Cylinder Head Kit	Description
1-E-H1-1K	High flow small block Chrysler	Relocated pushrod holes, wider intake ports, offset rocker arms. This TA style head kit includes: assembled heads, up to .600 lift springs, CNC bowl ports and gasket match, roller rockers (1.5 or 1.6 ratio) and shafts, clamps, shaft stud kit, 360-9K pushrod kit, 360-16 head bolts
EDE-H1-AS	Small block stock style Chrysler	Chrome moly retainers, 7 degree locks, seals, valve springs good up to .575 lift (63cc chambers, 171cc volume intake port)
1-E-H1-AS-M	Small block Chrysler Magnum	92 and later Magnum heads. 2.02 x 1.60 stainless valves, .575 lift springs, 58cc chambers, 176cc intake volume
1-E-H1-440AS	Big block Chrysler	Indy IE-440 assembled heads complete with 11/32 Indy 2.14 x 1.81 stainless valves, chrome moly retainers, 7 degree locks, seals, with up to .600" springs, 84cc chamber volume, 210cc intake port volume
1-E-H1-VIC	Edelbrock Victor big block Chry	Victor head bare, raised intake and exhaust ports, 75 cc chamber volume, 280cc intake port volume, 2.200 x 1.81 valves
EDE-H1-AMC	Edelbrock AMC stock style ass'y	Assembled heads complete with 2.02 x 1.60 stainless valves, springs up to .550 lift, 7 degree locks, chrome moly retainers, 3/8 rocker studs and 5/16 guide plates

**See page 11 of the price sheet for complete parts list and prices**

Open chamber 65cc



Closed chamber 63cc



**Edelbrock small block Chrysler**

### Hi flow small block Chrysler

Port .190" wider than the standard Edelbrock

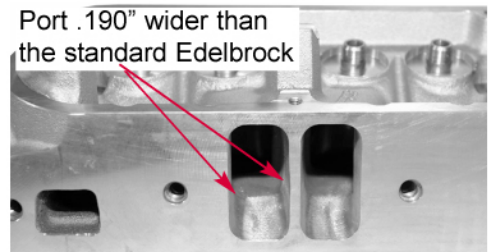

**We carry an extensive line of Indy Edelbrock engine parts:**

**Indy-Edelbrock high flow-A engine**

**Edelbrock-A engine**

**Indy-Edelbrock-360 Magnum engine**

**Edelbrock 440 engine**

**Edelbrock AMC-engine**

**Edelbrock carburetors and parts**

**Six shooter with Demon carbs and linkage**

Available for big block or small block



Hemi is a trademark of Chrysler corporation used for identification purposes only



# 440/400 B/RB Parts

440 Six Shooter with Demon carburetors for EZ or SR Indy heads



## 440-H1-1K Aluminum Head Kit



## Cylinder Head Kits

Part Number	Cylinder Head Kit	Description
440-H1-1K	Maxx Wedge aluminum head kit	Kit includes: 440-1AS aluminum head assembly, 440-7 or 8 valve covers, 440-14 thick wall shafts, 440-33 complete Fel-Pro gasket set, 400 or 440-14-2 or 3 manifold, 440-R4-11 rocker shaft stud kit, 440-P5-9K push rod kit, 400 or 440 V5-6 valley cover, 440-R4-4 rocker assembly(1.5 or 1.6 ratio), 440-R4-10 external oil kit
440-H1-CK	Maxx Wedge cast iron head kit	Kit includes: Cast iron head assembly, 440-7 or 8 valve covers, 440-14 thick wall shafts, 440-33 complete Fel-Pro gasket set, 400 or 440-14-2 or 3 manifold, 440-R4-11 rocker shaft stud kit, 440-P5-9K push rod kit, 400 or 440 V5-6 valley cover, 440-R4-4 rocker assembly(1.5 or 1.6 ratio), 440-R4-10 external oil kit
440-H1-SRK	Aluminum street replacement kit	Kit includes: 440-H1-SRAS head assembly, 440-P5-9K push rods, 440-R4-10 oil kit, 440-H3-16 head bolts, valley plate
572-H1-13K	Aluminum ICH head kit	Kit includes: 572-H1-13AS assembled heads, 440-V5-6R valley cover plate, intake and exhaust gaskets, full 100% CNC ported (365 or 385 cc) 440-V2-7S or 8S valve covers, Jessel rocker kit(1.55 or 1.7), 440-2 or 3 or 3x manifold, 440-9KJ push rod kit, external oil lines
600-H1-13XK	Aluminum ICH head kit	Kit includes: 600-13X assembled heads, 440-6R valley cover plate, intake / exhaust gaskets, Fully 100 CNC ported, spray bar sheet metal valve covers, Jessel rocker kit, 440-3X manifold, 440-9KJ push rod kit, Titanium valves, 2.20 valve springs, external oil lines

See page 12 of the price sheet for complete parts list and prices

## 440/400 Wedge Parts:

- Head bolts
- Gasket sets
- Assembled heads
- Bare heads
- Main caps
- Manifolds
- Belt drive pump kits
- Push rods
- Rockers
- Valley plates
- Valve covers
- Manifolds
- Valves

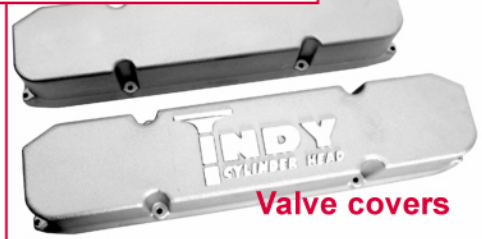

Hemi is a trademark of Chrysler corporation used for identification purposes only

# 440-EZ B/RB Parts



**475 to 750 HP Potential**

## About the 440 EZ Aluminum heads

The Indy Cylinder Head EZ heads are designed for A, B and E body cars. They have stock low exhaust port location and bolt patterns meaning that most standard exhaust headers will work. This means that if you want Indy power and want to use your existing stock exhaust headers, **this is the head for you!**

Like all Indy heads, EZ heads feature long valve design and a cast aluminum valley plate. More intake volume (280cc 440 EZ) equals more power.

There are four different EZ heads to choose from

### 440 EZ

Long valve stem design 270cc intake port volume  
 Stock exhaust port location  
 Stock intake opening  
 Stock pushrod location  
 Stock rocker arms  
 Stock rocker shaft oiling  
 2.19 x 1.81 valves  
 75cc closed or 80 cc open cbr

The as cast 440 EZ Indy head incorporates the original design raised intake runner and Indy aluminum valley plate. Stock 906 paper intake gaskets, stock exhaust gaskets and stock rocker arms are used. Angle spark plugs with standard low exhaust port and bolt pattern. This is a cure for common clearance problems.

### 440 EZ-1

Long valve stem design 275cc intake port volume  
 Stock exhaust port location  
 Stock rocker arms  
 Stock pushrod location  
 Stock rocker shaft oiling  
 2.19 x 1.81 valves  
 75cc closed or 80cc open cbr  
 CNC Max intake and bowl port

The 440 EZ-1 is the same cast head as the 440 EZ with the intake openings CNC machined to the Max Wedge size and CNC bowls. This allows all Indy manifolds to be used or all after market Max Wedge X-rams. Both EX and EZ-1 use standard Chrysler rocker shaft oiling. Standard low exhaust port.

### 440 EZ-295 CNC Little Easy

Long valve stem design 295cc intake port volume  
 Stock exhaust port location  
 Full CNC port 295 cc intake  
 Stock pushrod location  
 440-1 shaft oiling  
 Max Wedge intake opening  
 78cc closed or 82cc open cbr  
 2.19 x 1.81 valve 355 CFM

The **Little Easy** is the same cast aluminum head with full internal CNC porting. A high torque 295 cc Max intake runner and hi velocity low exhaust port. Must use 440-1 external shaft oiling. If you take off the cast iron 906 combo and add this **you will gain 100 hp.**

### 440 EZ-325 CNC Big Easy

Long valve stem design 275cc intake port volume  
 Stock exhaust port location  
 Full CNC port 325 cc intake  
 Stock pushrod location  
 Offset intake rockers needed  
 440-1 shaft oiling  
 78cc closed or 82 cc open cbr  
 2.19 x 1.81 valve 370 CFM

The **Big Easy** is an expanded version of the Little Easy. The main difference is the volume of the intake runner. Offset intake rockers are required with external shaft oiling. The Big Easy is a must for racers who want a 540 cubic inches combo in their A body car with low exhaust ports.

### 440 EZ CNC 295 or 325 cc Intake runner

See page 13 of the price sheet for other parts and pricing

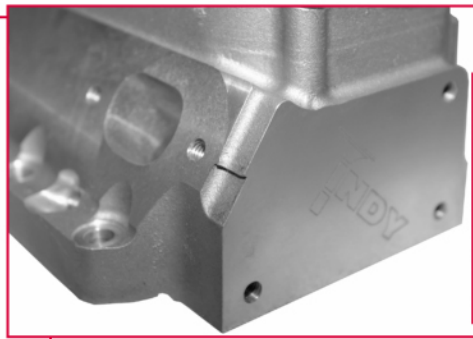
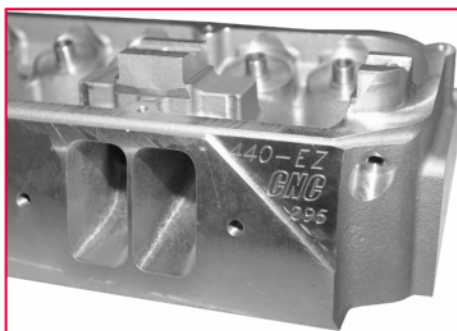

Hemi is a trademark of Chrysler corporation used for identification purposes only



# 426 Legend Parts

For a complete listing of the 426 cylinder heads and cylinder head kits see page 14 of the price sheet

## The 426-1 Legend aluminum heads

The legend lives on! Our biggest challenge to date was to design new life into an almost forgotten normally aspirated engine. Integral cast iron rocker stands, moveable rocker shafts, exhaust valve relocation, taller valve cover rail, .350" longer intake valve and raised intake and exhaust ports with superior airflow breathes new life in the redesigned Legend head from Indy Cylinder Head.

**Long valve design- feel the power!**

- Standard location and angle valves
- Standard exhaust port
- Integral rocker stands
- 170cc chamber volume
- 243cc intake port volume

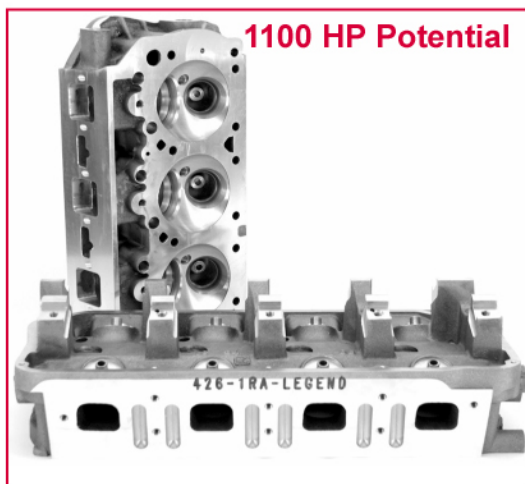
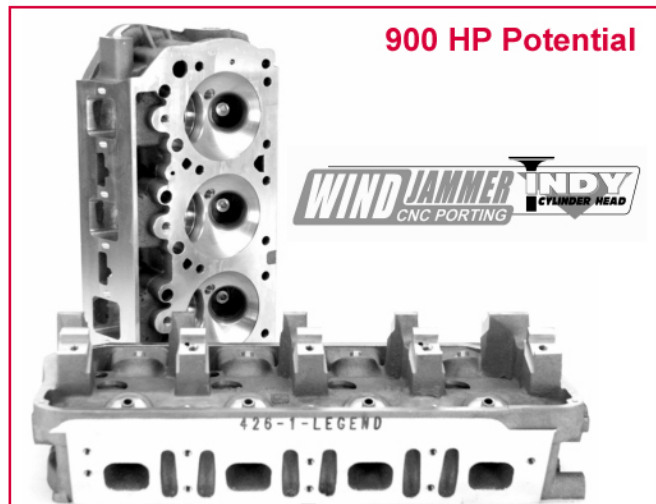

## The 426-1RA Legend aluminum heads

The 426-1RA legend head is a great choice for blown street machines or serious bracket racers that have tremendous horsepower needs. This head is best suited for a 500" cubic inch or larger bracket engine. Indy has incorporated a raised exhaust port to balance out intake to exhaust air flow percentages. This head also features an exhaust valve that has been relocated 2 degrees toward the cylinder wall in order to gain valve to valve clearance. This makes sinking valve jobs or cutting valves for clearance a thing of the past. Internal rocker stands along with Indy 426-7 rocker rollers make this a superior combination.

- Moved exhaust angle and raised port
- Integral rocker stands
- 170cc chamber volume
- 251cc intake port volume

## The 426-1RA6 Legend aluminum heads

The 426-1RA6 is a serious legend head for bigger cubic inch engines. Take for example a 605" cid or 636" cid which need every bit of the 500 cfm airflow and 325 cc intake port volume to produce loads of horsepower. This head has all the good features: +.350" longer intake valve, raised intake port, integral rocker stands, exhaust valve rotated 2 degrees toward the cylinder wall and raised exhaust ports. Build a 605 cid engine with our 426-4 4500 big volume intake and watch out...you'll have a 1,000 HP single four barrel monster on your hands.

- Moved exhaust angle and raised exhaust ports
- integral rocker stands
- 2.100" wide x 2.200" tall 10 bolt intake port
- 160cc chamber volume
- Flat face valves
- 325cc intake port volume

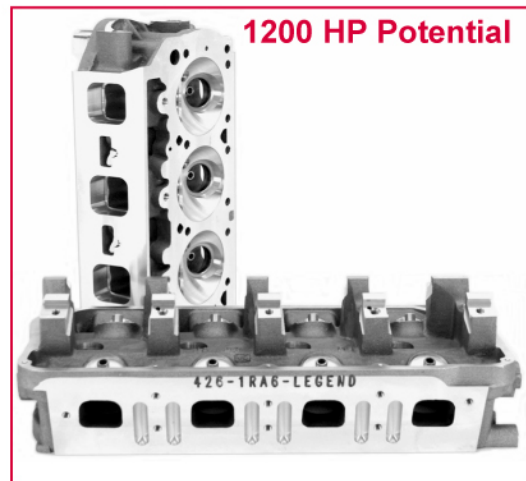

Hemi is a trademark of Chrysler corporation used for identification purposes only

# 426 Legend Parts



## Billet Legend Aluminum Heads

### 2500 HP Potential



The Billet Legend head is a product of countless hours of research and development both in house and at the track. This head features one of the largest volume intake ports for a Hemi in the industry (330cc!). This, along with longer intake valves and raised intake runners provides great airflow characteristics. The Billet Legend is a great choice for Pro Mod, tractor pulling, monster trucks, or any blown alcohol application.

Where else in the country can you purchase heads for your blown alcohol race car and on the same order buy heads for the truck you pull it to the track with? Nowhere but Indy!

**Moved exhaust angle and raised exhaust port**  
**Integral rocker studs**

**2.300" wide x 2.350" tall 10 bolt big intake port**  
**160cc chamber volume checked with flat face valves**  
**325cc intake port volume for large C.I.D. engines**

### Hemi valve cover



Available in aluminum or black power coated



### Gasket sets

Because the Hemi is off center, installation into a classic muscle car presents a valve cover clearance problem. We have a solution to this problem with our specially designed Hemi cover that helps clear the heater motor and shock tower.

**We custom engrave the Indy logo on our covers**

### Other 426 Legend Parts

See page 14 of the price sheet for a complete listing of 426 parts and accessories

- Bolts
- Gaskets
- Manifolds
- Rockers
- Push rods
- Valve covers
- Valves

**See page 14 of the price sheet for complete parts list and prices**

### 2000 CFM EFI

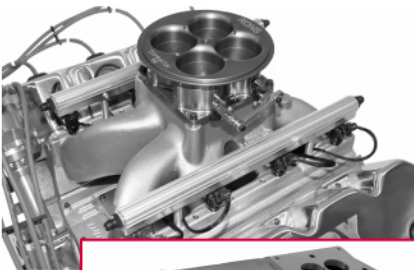

**426-8 Cross Ram**

### Aluminum Blower Manifold

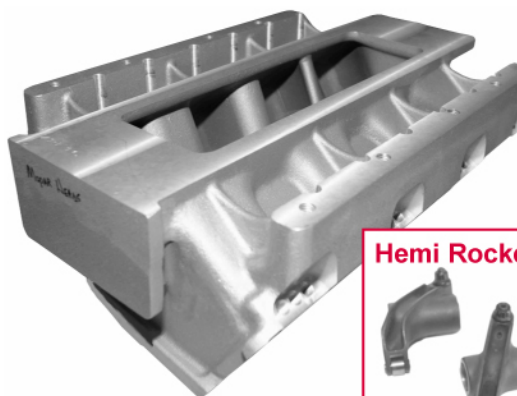

### Hemi Rockers



1.6 Intake  
 1.5 Exhaust

### 426-5 Tunnel Ram with Enderle F.I.

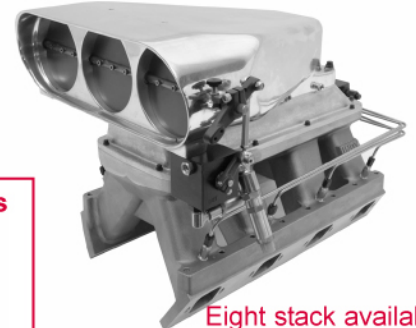

Eight stack available

Hemi is a trademark of Chrysler corporation used for identification purposes only



# 392/426 New Legend Hemi

Based off the new 5.7 / 6.1 Hemi

See page 16 of the price sheet for complete New Hemi 392 and 426 specifications, parts and prices

## 426 New Hemi Street Legend 565HP

Through extensive engineering we've taken the new 6.1 Hemi and upgraded it to the 426" and the 5.7 to a 392". In doing so we're giving you raw horsepower of the past with improved fuel economy, clean exhaust and great performance of the present. The perfect crate engine for Mopar enthusiast or the street rodder on the cutting edge.

**Dyno tested and tuned**



4.090" bore, 4.050" stroke Pump gas

- Fully prepped 6.1 block      Billet main caps      ARP main and head studs
- Compstar 4340 crank (4.050" stroke)      Compstar H Beam rods (6.125")
- Mahle coated pistons      6.1 heads,      Manly springs and retainers
- Fully CNC ported (370 cfm)      2.08 x 1.60 valves      Indy 426 name plate
- 6.1 intake CNC port matched      Outside and inside intake polished
- ATI balancer      Stroker windage tray      Comp Hyd roller cam



## New Legend Short Block

- Machined 6.1 block
- 4.090" bore
- Billet main caps
- Compstar crank
- Compstar H Beam rods
- Mahle coated pistons (10.3 to 1)
- Rings, bearings, internal balanced
- ARP main and head studs
- Assembled

Ready to ship!

## New Legend Rotating Kit



- Compstar crank (4.050" x 2.100)
- Compstar H Beam rods (6.125 x .927)
- Mahle coated pistons (10.3 to 1)
- Rings, bearings
- Internal balanced

## Check out these Indy Features



All 4.050" Stroker cranks are gun drilled. All four rod pins are drilled to remove weight. New billet toner wheels are standard.



Notice the dual keys for the harmonic damper or blower drive hub. This is **not** found on a stock crank!



The 4.050" stroke crank in the rotating kit will fit either the 6.1 / "426" or the 5.7 / "392" cu in.

6.1: # 6.1-R6-426  
5.7: # 5.7-R6-392



Steel billet main caps with ARP main studs and 12 point nuts. Replaces powdered metal caps on stock 6.1 blocks. Black oxide finish.



Only 55 lbs!

Callies 4340 material crankshafts are 1200 horsepower rated and weigh only 55 lbs! New billet toner wheel and two keys for the balancer.



State of the art 5 axis porting assures these are the best flowing heads available. 370 cfm with a standard 2.080 intake valve.



We also offer complete crate motors, assembled short blocks and rotating kits for the 392 / 5.7...see page 16 of the price sheet for all the details

CNC 5 Axis Head Porting...see page 16

Hemi is a trademark of Chrysler corporation used for identification purposes only



# 392 / 426 New Hemi Parts



## 392 / 426 New Hemi Parts for the 5.7 / 6.1

We carry an extensive line of parts for the new 392 / 426 Hemi. See page 16 of the price guide for a full listing:

- Billet main caps
- Main studs
- Head studs
- Compstar cranks
- Compstar H-Beam rods
- Mahle coated pistons
- Rod bearings
- Main bearings
- Camshafts
- Balancers
- Head gaskets
- Polished beehive springs
- Titanium retainers
- Chrome moly push rods
- Oil pumps
- Oil pans
- Fast fuel injection kits
- TTI headers

CNC 5 axis head porting

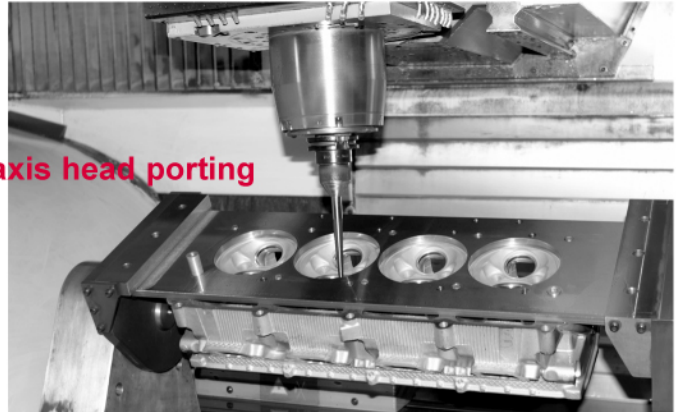

ATI Balancer

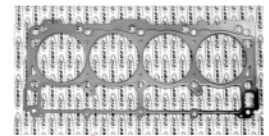

Gaskets

Mahle coated pistons



Head bolts and studs

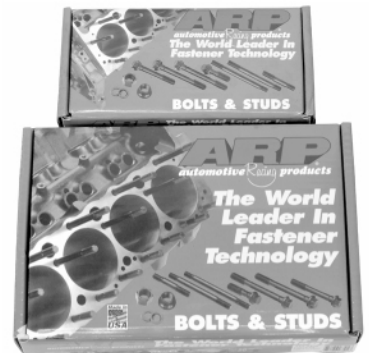

ECU wiring Harness



Oil pans and pick ups



FAST 90mm throttle bodies

Compstar crankshaft



See page 14 of the price sheet for complete parts list and prices

Hemi is a trademark of Chrysler corporation used for identification purposes only



# New and Special Items for 2007

## Billet Accessories

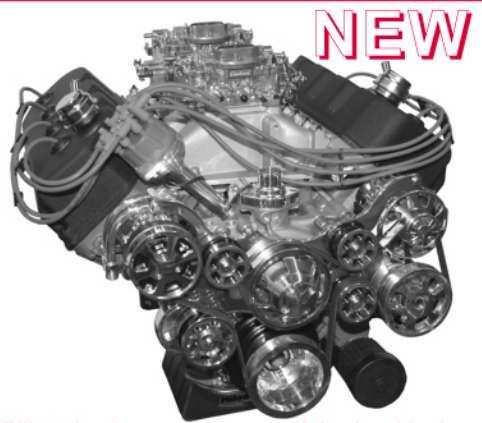

Billet aluminum package-polished or black

## The "Who's Next?" Goldberg special edition engine

In the fall of 2007 we produced a limited number of "Who's next?" Goldberg Hemi engines. This 650 horsepower monster is just one example of the type exceptional engineering we are capable of. Watch for future Indy Cylinder engine buildups.



## Who's Next?

### The Limited Edition "Who's Next" 526" Street Legend

650 Horsepower / 625 Torque



Engraved valve covers



Indy Cylinder Head and Bill Goldberg have teamed up to design this incredible 526" Street Legend engine based on the 426 Hemi. Indy will only manufacture and sell 20 of these engines at a special price. Don't wait...once they are gone, that's it.

MSD distributor and wires



Mighty Demon carb with bracket  
Demon fuel line

Black powder coat top end package

Stainless steel polished hardware



CNC bowl port and gasket match

Eagle H-Beam rods (7.100/2.2)

Indy 426-1 Legend heads

Forged 10.25 to 1 pistons

Eagle 4340 crank (4.500 / 2.2)

Indy 426-7 roller rockers (1.6/1.55)

4.310" bore / 4.500" stroke  
Thick cylinder walls

Fully prepped Mopar iron block

Comp hydraulic cam  
.560/.543---.253/.253-H108

System One filter

*Dyno Tested and Tuned*

Hemi is a trademark of Chrysler corporation used for identification purposes only

# CYLINDER HEAD KITS

Cylinder head kits with everything you need to get that horsepower gain of pure *Indy power*. Packages includes everything between the block and the carburetor

